



City of University Park, Texas

VEHICLE PROCUREMENT REQUISITION (VPR)

Date 10/24/56

INSTRUCTIONS: Department manager– complete the header portion of this form and forward the VPR to the Fleet Manager. This document and its attachments serve as the official requisition for a vehicle and ensure that all approvals have been made.

Vehicle description: Cemen Tech 6 yard mobile concrete mixer.

User Department Infrastructure Maintance

Type of purchase:

- 1. Planned replacement
- 2. Early replacement
- 3. Upgrade
- 4. Addition

Dept. mgr. signature _____

Dept. head signature *Keeg Little*

Anticipated City Council meeting approval date: _____

1. Initial Request

User Department or Fleet Manager submits VPR. User department includes brief written attachment describing need for and intended use of vehicle (not required for planned replacement of like equipment).

2. Specifications

Fleet Manager reviews request and assists user department with development of vehicle specifications. Fleet Manager approves specs.

Car *[Signature]*

Fleet Manager

Date

3. Assemble prices

Purchasing Agent and Fleet Manager assemble quotes, conduct bid process, or collect pricing from cooperative purchasing contracts. Purchasing Agent copies information to user department, who reviews and makes selection by signing below.

Keeg Lathwell 12/20/24
 User Department Date

4. Executive approval

Fleet Manager forwards VPR and supporting documents to Finance Director and City Manager for approval, who forward VPR to Purchasing Agent.

[Signature] 12/30/24
 Director of Finance Date

[Signature] 12/30/24
 City Manager Date

5. Agenda preparation

Purchasing Agent prepares agenda memo regarding compliance with City purchasing policy and State purchasing law and submits to City Secretary along with user department memo and bid tabulation.

 Purchasing Agent Date

6. City Council Approval

 Date

7. Purchase Order execution and order placement

Purchasing Agent sets up Purchase Order and places order with vendor. Purchasing Agent sends PO copy to Fleet Manager

8. Vehicle delivery and acceptance

Vendor delivers vehicle to Equipment Services Division. Fleet Manager or designee accepts delivery and approves payment of invoice for vehicle. Fleet Manager forwards approval to Accounts Payable Specialist for payment.



PURCHASE ORDER

22316

SOLD TO: **Company:** University Park
Contact: University Park
Address:

SHIP TO: University Park

Cell No:
Phone No.:
Date: 6/11/2024
Sales Person: ROMCO PAVING EQUIPMENT

Ship Method: CUSTOMER TO ARRANGE
 E.X.W Factory-Indianola, Iowa

MODEL	DESCRIPTION	BASE PRICE
M30	PRODUCE UP TO 30 CUBIC YARDS OF CONCRETE PER HOUR	98,417
OPTIONS INCLUDE:		Qty
SOURCEWELL PURCHASE		1 0
<ul style="list-style-type: none"> GOVERNMENT ENTITIES CAN PURCHASE CEMEN TECH EQUIPMENT DIRECTLY THROUGH SOURCEWELL, A COOPERATIVE PURCHASING AGENCY, ELIMINATING THE REQUIREMENT OF SOLICITING A BID. CEMEN TECH CONTRACT #060122-CMT. 4% DISCOUNT APPLIED TO TOTAL PURCHASE PRICE. 		
6 YARD PACKAGE		1 2,310
<ul style="list-style-type: none"> INCLUDES 6 YARD BIN, 65 CUBIC FOOT CEMENT BIN AND 430 GALLON WATER TANK 		
SPRAY ON AGGREGATE BIN LINER		1 5,157
<ul style="list-style-type: none"> SPRAY ON HEAVY DUTY TWO COMPONENT MODIFIED POLYUREA PROTECTIVE COATING. PROTECTS AND SEALS AGGREGATE BIN TO ADD WEARD LIFE AND PREVENTS CORROSION. 		
360° SWIVEL CHUTE		1 1,567
<ul style="list-style-type: none"> 360° SWIVEL CHUTE WITH 24" SHORT CHUTE. ACCEPTS STANDARD MIDDLE AND END CHUTES. 		
ACCU-PRINTER II (AP2)		1 7,690
<ul style="list-style-type: none"> ADVANCED SECOND GENERATION ELECTRONIC TICKET PRINTER THAT EXPANDS THE CAPABILITIES OF THE ORIGINAL ACCUPRINTER. TOUCHSCREEN DISPLAY ALONG WITH THE ABILITY TO STORE MORE MIX DESIGNS AS WELL AS UPLOAD MIX DESIGNS AND DOWN LOAD MIX DATA THROUGH USB PORT. INCLUDES WATER RECORDING METER AND TICKET PRINTER. 		
CALIBRATION KIT (1/4 YARD)		1 573
<ul style="list-style-type: none"> 1/4 YARD ALUMINUM, COLLAPSIBLE YIELD BOX WITH DIGITAL SCALE AND MEASURING CUPS TO AID IN CALIBRATION OF THE UNIT. 		
CAMERA - REAR VIEW ONLY		1 1,183
<ul style="list-style-type: none"> REAR VIEW CAMERA WITH IN-CAB DISPLAY AND LIVE VIEW ONLY. NO DVR. 		
HYDRAULIC OIL COOLER-AIR		1 2,994
<ul style="list-style-type: none"> FAN OIL COOLER TO LOWER HYDRAULIC OIL TEMPERATURE FOR OPERATION IN HIGH AMBIENT HEAT CONDITIONS, EXTENDED OPERATION, OR WHEN MIX WATER CAN NOT BE USED. 		
MIXER DIAPER		1 344
<ul style="list-style-type: none"> MIXER DIAPER UNDER MIXING THROAT TO CATCH MATERIALS AND PREVENT THEM FROM SPILLING. STANDARD COLOR IS YELLOW. 		
ONSITE DEALER STARTUP		1 5,835
<ul style="list-style-type: none"> ONSITE CUSTOMER STARTUP PERFORMED BY CEMEN TECH DEALER. EXPIRES IF NOT USED WITHIN 1 YEAR. 		



PURCHASE ORDER

22316

STROBE LIGHTS - ONE FRONT & ONE REAR	1	1,011
<ul style="list-style-type: none"> ONE FRONT AND ONE REAR MOUNTED STROBE CAUTION LIGHT. STROBE WILL BE MOUNTED ON THE BACK OF THE UNIT ON THE DRIVER'S SIDE, AND ON THE FRONT WATER TANK CAGE. SWITCH LOCATION WILL BE LOCATED IN THE CAB IF THE UNIT IS MOUNTED ON A TRUCK CHASSIS. THE SWITCH WILL BE LOCATED IN THE MIXER CONTROL PANEL IF THE UNIT IS MOUNTED ON A TRAILER. 		
TARP - BLACK MESH	1	3,241
<ul style="list-style-type: none"> ELECTRIC MOTOR OPERATED MESH TARP TO HELP SECURE YOUR AGGREGATES DURING TRANSIT. SWITCH WILL BE MOUNTED ON THE BIN SUPPORT. 		
THIRD ADMIXTURE SYSTEM (HIGH RANGE)	1	1,611
<ul style="list-style-type: none"> USED FOR ADMIXES THAT REQUIRE 5 OUNCES OR MORE ADDITION RATE PER 100 LBS OF CEMENT. THE ADMIX MUST BE DILUTED TO ACHIEVE PROPER CONSISTENCY AND FLOW RATE THROUGH THE FLOW METER. SYSTEM INCLUDES A 35 GALLON (132 LITER) POLY TANK, ELECTRIC PUMP AND MECHANICAL FLOW METER WITH BUILT IN ADJUSTABLE SETTINGS. 		
TRANSMISSION INTEGRATION - AUTOMATIC (INCLUDES ROLL AND POUR CAPABILITY)	1	1,578
<ul style="list-style-type: none"> TRANSMISSION INTEGRATION - AUTOMATIC (INCLUDES ROLL AND POUR CAPABILITY) 		
VIBRATORS - STONE SIDE	1	1,023
<ul style="list-style-type: none"> STONE SIDE VIBRATORS ENSURE FLOW OF FINE MATERIALS AND SMALLER STONE SHOULD THEY BE REQUIRED FOR SPECIAL MIX DESIGNS. COMMONLY USED IN FLOWABLE FILL AND LATEX APPLICATIONS. 		
WIRELESS REMOTE CONTROL	1	5,652
<ul style="list-style-type: none"> FULL FUNCTION WIRELESS REMOTE CONTROL TO OPERATE THE UNIT INDEPENDENT FROM THE CONTROL PANEL. INCLUDES E-STOP BUTTON IN CONTROL PANEL. 		
<u>TRUCK & TRAILER SECTION:</u>	<u>Qty</u>	<u>Price</u>
MOUNTING - CTI SUPPLIED TRUCK	1	4521.00
<ul style="list-style-type: none"> CEMEN TECH PROVIDED CHASSIS. PROVIDE QUALITY WORKMANSHIP AND PROPERLY MOUNT UNIT TO APPROPRIATE CHASSIS. 		
TRUCK PURCHASE	1	124434.00
<ul style="list-style-type: none"> 2025 Freightliner M2-106+ Cummins L9 – 350hp Allison 3000RDS 18K Front 40K Rears 40K Hendrickson Haulmaax 135" CT 		

NOTE: Standard unit color is white.
Standard Chassis color is white.

Base Unit Price: 98,417

Unit Options Total: 41,769

Less Discount: 5,607.44

Unit Total Price: **134,578.56**

FREIGHT CHARGE INCLUDES: Acquisition freight from factory to ROMCO / Make Ready / PDI / Delivery **
SUBJECT TO PRIOR SALE ** Contract #060122-CMT

Truck | Trailer Section Total: 128,955.00

Est. Freight Amount: 6,500.00



PURCHASE ORDER

22316

Total Per Unit:	\$270,033.56
Quantity:	1
TOTAL:	\$270,033.56

Currency - USD

- Any applicable taxes and fees are the responsibility of the customer
 - Changes to the order after acceptance will incur additional charges
 - The remainder of 20% deposit balance is due 30 days prior to start of production
 - For all custom color mixers and chassis, a 20% deposit is required due at time of signing the order.
- Any orders containing custom color chassis and/or mixers are non-cancellable after time of order.
-

CONTROL YOUR CONCRETE™

WITH THE M30 CONCRETE MIXER

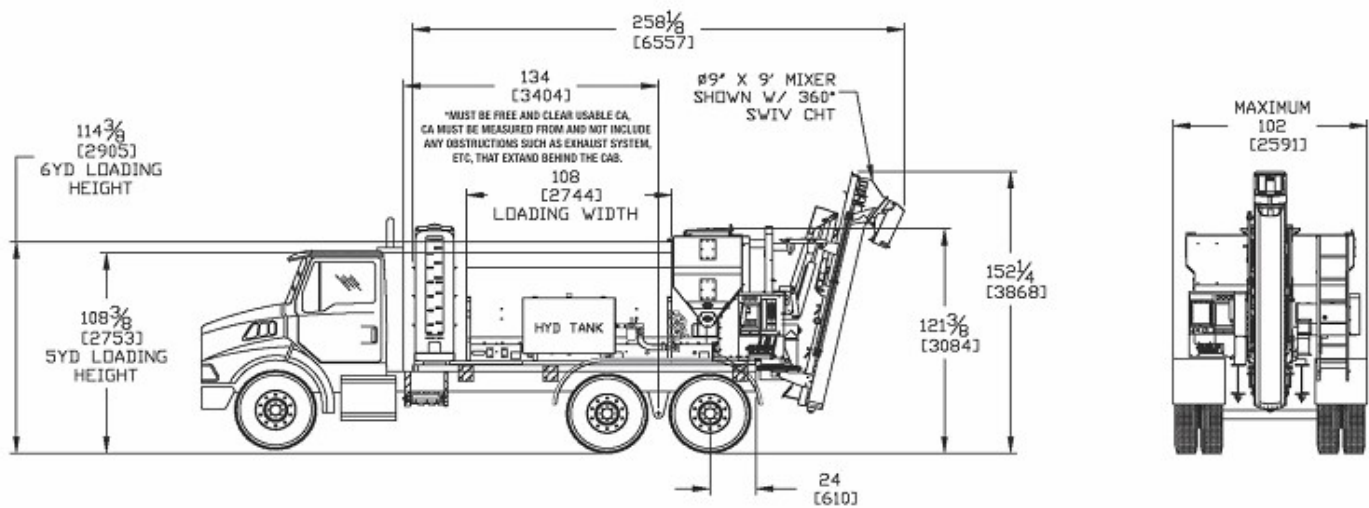

6 Yard Specifications

AG-BIN CAPACITY	204 cu ft/5.78m ³
CEMENT BIN CAPACITY	65 cu ft/1.84 m ³
PRODUCTION CAPACITY	6 cu yd/4.6 m ³
PRODUCTION RATE	30 yd/hr/22.94 m ³ /hr
MIXER DIAMETER	9 inches/.23 meters
MIXER SPEED (MAX)	330 RPM
HYDRAULIC TANK CAPACITY	65 Gal/246 L
CONVEYOR SPEED (MAX)	40 RPM
WATER TANK (Baffled)	430 Gal/1627 L
HIGH FLOW ADMIX TANK	35 Gal/132.4 L
LOW FLOW ADMIX TANK	12 Gal/45.4 L
POWER SWIVEL	149 Degrees

*Specifications provided are approximations
*Standard unit color is white

ADDITIONAL FEATURES

- Red Lion Digital Counter
- Center Divider
- Dual Auger Cement Metering
- 2 Speed Cement (20%)
- Two Additional Chutes
- Sand and Cement Vibrators
- Chain Oiler
- Mixer Diaper Hooks
- Bolt-On 42" First Chute
- Pumpmaster Auger w/Max Life Bearing



PROVEN PROCESS

How to Succeed with Volumetric Technology



**CONTROL
YOUR CONCRETE™**

BENEFITS OF VOLUMETRIC TECHNOLOGY

TAKE CONTROL OF YOUR CONCRETE

Eliminate the dependency on local Ready Mix Producers; deliver where and when you want.

ADOPT TECHNOLOGY EASIER by having Cemen Tech walk you through the start-up process to ensure your employees are trained and operating the equipment effectively.

INCREASE YOUR VERSATILITY to get more projects done faster. No more waiting - complete the project on your schedule.

MINIMIZE YOUR RISK

Maximize uptime through our innovative technical support tools and representatives so your investment is operating at full capacity.

MANAGE YOUR NEW EQUIPMENT

Utilize ACCU-POUR™ software to maximize the return on your investment (ROI) and understand exactly what your investment is doing every day.

GAIN MORE KNOWLEDGE with a customized training plan to ensure the transition to your new solution goes smoothly.

INCREASE YOUR FLEXIBILITY to win more bids and gain access to more working capital by reducing your material costs.

WHAT WE OFFER OVER OUR COMPETITION

Cemen Tech provides customers proven value that industry competitors simply cannot. The units may be slightly cheaper, but when you take into account all the additional value you get by purchasing a full business solution from Cemen Tech, your success in concrete is guaranteed.



THE BREAKDOWN

Utilize Tech to Gain Efficiencies	\$10,680
Market Your Business Better	\$28,080
Highest Resell Value	\$20,000
User Group Access	\$28,080
Minimize Mistakes	\$5,616
Full Solution Knowledge	\$11,700
Real-Time Video Support	\$7,020
Faster Parts Availability	\$11,700
Improved Cement Accuracy	\$5,616
Improved Aggregate Accuracy	\$5,616
Maximize Productivity	\$9,360
Industry Best Training	\$2,340
Stock Available for Fast Delivery	\$11,700

ADDITIONAL VALUE \$157,508

**CONTROL
YOUR CONCRETE™**



**We Have
The Solution**

Cemen Tech Equipment Financing

We are committed to your financial success. Our solutions combine convenience and seamless service with flexibility, backed by industry experience and in-depth product knowledge.

Convenient

We know your time is valuable. We streamline the process to save you time and effort to allow you to focus on your business.

Flexibility

We recognize that every business is different and unique set of needs. We will work with you to find the solution that align with your goals.

Industry experience

Our team brings extensive industry experience helping you navigate the complexities of equipment financing.

Committed

Our unwavering commitment is centered on your success. As part of the Cemen Tech family we are focused on changing the industry and changing people's lives.

CEMENTTECHCAPITAL.COM

TERMS AND CONDITIONS OF SALE

1. **Parties.** Cemen Tech, Inc. is identified herein as "seller". The party purchasing the items described is identified as "purchaser".
2. **Prices.** Prices quoted by the seller are guaranteed for thirty (30) days from the Quote Date on the front of the purchase order. Prices are subject to change on purchase orders received in our office thereafter. Payment of the purchase price is to be performed at the seller's place of business. 1700 North 14th Street, Indianola, Iowa.
3. **Acceptance.** The purchase order is subject to approval and acceptance by the seller at its office in Indianola, Iowa.
4. **Taxes.** Purchaser is responsible for the payment of all sales and use taxes.
5. **Warranties.** The seller warrants that it will repair or replace, without charge, any part that is defective in workmanship or material and is returned to the seller at Indianola, Iowa, freight prepaid, within three hundred sixty-five (365) days of delivery to the purchaser. SELLER MAKES NO WARRANTIES EXPRESS OR IMPLIED, INCLUDING WARRANTIES AS TO THE MERCHANTABILITY OR AS TO THE FITNESS FOR ANY PARTICULAR USE OR PURPOSE, EXCEPT THE ABOVE EXPRESS WARRANTY, AND THERE ARE NO WARRANTIES WHICH EXTEND BEYOND THE DESCRIPTION ON THE FACE HEREOF. SELLER SHALL NOT BE LIABLE FOR ANY LOSS OR DAMAGE, DIRECTLY OR INDIRECTLY, ARISING FROM THE USE OF SUCH EQUIPMENT OR FOR CONSEQUENTIAL DAMAGES. Purchaser's exclusive remedy shall be repair or replacement of defective parts and in no event whatsoever shall seller be otherwise liable. This warranty does not apply to chassis or other components or parts that are not manufactured by seller. Such chassis, components, and parts may be covered by a warranty provided by their respective manufacturers. Progressive, incidental, or consequential damage caused by these manufacturers' components to any other parts including, but not limited to, parts installed by seller is excluded from seller's warranty coverage.
6. **Axle loading disclaimer.** Legal axle loading (weight) is governed by federal, state and local regulations. The choice of an appropriate chassis is strictly the purchaser's decision, and it will affect the allowable carrying capacity of seller's equipment. Axle loading restrictions vary by locality as well as the type of roadway and the time of year. It is the purchaser's sole responsibility to be familiar with and follow axle loading restrictions wherever the purchaser operates seller's equipment. The seller does not warrant its equipment to be compliant with any axle loading restrictions.
7. **Payment and interest.** Unit must be paid for in full within 15 days of the completion date to avoid interest and storage charges of \$500 USO per week. After 45 days, the Purchaser may forfeit their deposit and Seller reserves the right to resell the unit at the Purchaser's expense.
8. **Attorney(s) fees and expenses.** Purchaser shall pay seller's reasonable attorney's fees and expenses incurred in enforcing or defending this agreement and claims related thereto.
9. **Business use.** Purchaser warrants that the subject equipment is being purchased for use primarily in business, and not for personal, family or household purposes.
10. **Representations.** This purchase order constitutes the complete agreement between the parties and cannot be amended or modified except by a written statement signed by the parties. Sales representatives do not have the authority to amend, modify, or waive the printed terms and conditions stated therein. Additional fees ranging from \$500 - \$2,000 may be applied to the final invoice if any modifications are needed after receipt of the signed order; these fees will be in addition to the cost of any modifications.
11. **Captions.** Captions appearing herein are for convenience purposes only and do not alter or affect the interpretation or construction of any paragraph herein.
12. **Savings clause.** If any provision herein is deemed to be unconscionable or unenforceable for any reasons, the remaining provisions of the agreement shall remain in force, or the agreement shall be cancelled at the sole discretion of the seller.
13. **Place of contracting.** This purchase order is deemed by the parties to have been accepted and entered into the State of Iowa and will be interpreted under the laws of the State of Iowa.
14. **Venue.** The parties hereby agree that Warren County, Iowa, is an appropriate and convenient forum for any action brought to enforce the terms and conditions of this agreement.
15. **Non Solicitation.** The direct Purchaser and/or final Purchaser of the Products agree that they will not solicit Seller's personnel for purposes of employment for a period of two (2) years following their most recent Purchase Order. In the event Purchaser(s) hires a current employee of Seller, Purchaser(s) shall be liable to Seller for damages equal to one (1) year's wages of the employee hired.
16. **Shipping.** Shipping terms will be E.X.W Indianola, Iowa.
17. For all custom color mixers and chassis, a 20% deposit is required due at time of signing the order. Any orders containing custom color chassis and/or mixers are non-cancellable after time of order.

Accepted By: Romco Equipment Co. LLC

Authorized By: _____
(Authorized Signature)

Title: _____

Date: _____

Accepted By: _____

Authorized By: _____
(Authorized Signature)

Title: _____

Date: _____