

ORDINANCE NO. _____

AN ORDINANCE OF THE CITY OF UNIVERSITY PARK, TEXAS, AMENDING THE COMPREHENSIVE ZONING ORDINANCE AND MAP OF THE CITY OF UNIVERSITY PARK, AS HERETOFORE AMENDED, FOR THE PROPERTY DESCRIBED AS LOT 8R, BLOCK B, WINDSOR PLACE ADDITION, AN ADDITION TO THE CITY OF UNIVERSITY PARK, DALLAS COUNTY, TEXAS, COMMONLY KNOWN AS THE HIGHLAND PARK PRESBYTERIAN CHURCH, 3821 UNIVERSITY BOULEVARD, BY AMENDING PLANNED DEVELOPMENT DISTRICT NO. 36 TO AUTHORIZE EXPANSION OF AN EXISTING COLUMBARIUM; APPROVING AN AMENDED DETAILED SITE PLAN; PROVIDING SPECIAL CONDITIONS; PROVIDING FOR THE REPEAL OF ALL ORDINANCES IN CONFLICT; PROVIDING A SEVERABILITY CLAUSE; PROVIDING FOR A PENALTY OF FINE NOT TO EXCEED THE SUM OF TWO THOUSAND DOLLARS (\$2,000.00) FOR EACH OFFENSE; AND PROVIDING AN EFFECTIVE DATE.

WHEREAS, the Planning and Zoning Commission and City Council of the City of University Park, in compliance with the laws of the State of Texas with reference to the granting of zoning classifications and changes, have given the requisite notices by publication and otherwise, and have held due hearings and afforded a full and fair hearing to all property owners generally and to all persons interested and situated in the affected area and in the vicinity thereof, and the City Council is of the opinion and finds that said zoning change should be granted and that the Comprehensive Zoning Ordinance and Map should be amended; **NOW, THEREFORE**,

BE IT ORDAINED BY THE CITY COUNCIL OF THE CITY OF UNIVERSITY PARK, TEXAS:

SECTION 1. That the Comprehensive Zoning Ordinance and Map of the City of University Park, Texas, are hereby amended by approving an amended Detailed Site Plan for Planned Development District No. 36 (“site plan”) on the property described as Lot 8R, Block B, of Windsor Place Addition, an addition to the City of University Park, Dallas County, Texas, and commonly known as 3821 University Boulevard, the Highland Park Presbyterian Church.

SECTION 2. That the site plan, attached hereto collectively as Exhibit “A” (2 pages) and made part hereof, is hereby approved as required by Section 9.5.3 of the Comprehensive Zoning Ordinance of the City of University Park, Texas, subject to the following special conditions:

- a. The Church will construct an expansion of the existing columbarium by adding approximately 680 new niches, in an existing courtyard east of the Sanctuary and enclosed by buildings on all sides. The expansion includes 4 new columbarium walls ranging in height, from 3'6" to 7'5". In addition, the expansion will include new site paving, a water feature, and new landscaping to match the existing palette, as shown on the columbarium plans, attached collectively as Exhibit "B"(2 pages) attached hereto and made part hereof;
- b. The columbarium will have existing trees and planting beds with evergreen shrubs, as shown in Exhibit "C" (6 pages) attached hereto and made part hereof;
- c. Details of the sculpture placement, water feature, and elevation renderings of the proposed niches are provided in Exhibit "D" (6 pages)
- d. Columbaria in Texas are regulated as cemeteries by Chapter 711 of the Texas Health & Safety Code and the provisions of that chapter, as amended from time to time, are incorporated herein by reference; this columbarium will be operated and maintained in accordance with said chapter and any rules, regulations or bylaws adopted pursuant thereto by the Highland Park Presbyterian Church;
- e. The property shall be developed only in conformance with the requirements of the Planned Development ordinance creating PD-36, any amendments thereto, including this one, and the approved site plan;
- f. Background checks will be performed by the contractors for all construction workers prior to their working on the site. Information relating to background checks will be kept on file by the Contractor. A convicted felon or pedophile will be barred from working on the site.

SECTION 3. All ordinances of the City in conflict with the provisions of this ordinance are hereby repealed.

SECTION 4. Should any sentence, paragraph, subdivision, clause, phrase or section of this ordinance or the Comprehensive Zoning Ordinance and Map, as amended hereby, be adjudged or held to be unconstitutional, illegal or invalid, the same shall not affect the validity of this ordinance as a whole or any part or provision thereof, other than the part so declared to be invalid, illegal or unconstitutional, and shall not affect the validity of the Comprehensive Zoning Ordinance as a whole.

SECTION 5. Any person, firm or corporation violating any of the provisions of this ordinance or the Comprehensive Zoning Ordinance and Map, as amended hereby, shall be deemed guilty of a misdemeanor and, upon conviction in the municipal court of the City of University Park, Texas, shall be punished by a fine not to exceed the sum of two thousand dollars (\$2,000.00) for each offense, and each and every day any such violation shall continue shall be deemed to constitute a separate offense.

SECTION 6. This ordinance shall take effect immediately from and after its passage and the publication of the caption, as the law and Charter in such cases provide.

DULY PASSED by the City Council of the City of University Park, Texas, on the 1st day of October 2024.

APPROVED:

TOMMY STEWART, MAYOR

ATTEST:

CHRISTINE GREEN, CITY SECRETARY

APPROVED AS TO FORM:

ROBERT L. DILLARD III, CITY ATTORNEY

ORDINANCE NO. _____

AN ORDINANCE OF THE CITY OF UNIVERSITY PARK, TEXAS, AMENDING THE COMPREHENSIVE ZONING ORDINANCE AND MAP OF THE CITY OF UNIVERSITY PARK, AS HERETOFORE AMENDED, FOR THE PROPERTY DESCRIBED AS LOT 8R, BLOCK B, WINDSOR PLACE ADDITION, AN ADDITION TO THE CITY OF UNIVERSITY PARK, DALLAS COUNTY, TEXAS, COMMONLY KNOWN AS THE HIGHLAND PARK PRESBYTERIAN CHURCH, 3821 UNIVERSITY BOULEVARD, BY AMENDING PLANNED DEVELOPMENT DISTRICT NO. 36 TO AUTHORIZE EXPANSION OF AN EXISTING COLUMBARIUM; APPROVING AN AMENDED DETAILED SITE PLAN; PROVIDING SPECIAL CONDITIONS; PROVIDING FOR THE REPEAL OF ALL ORDINANCES IN CONFLICT; PROVIDING A SEVERABILITY CLAUSE; PROVIDING FOR A PENALTY OF FINE NOT TO EXCEED THE SUM OF TWO THOUSAND DOLLARS (\$2,000.00) FOR EACH OFFENSE; AND PROVIDING AN EFFECTIVE DATE.

DULY PASSED by the City Council of the City of University Park, Texas, on the 1st day of October 2024.

APPROVED:

MAYOR

ATTEST:

CITY SECRETARY

Exhibit "A"

AREA SUMMARY	
DEVELOPMENT BOUNDARY AT GRADE TRACT I **	201,522 SF
LOT COVERAGE	49%
GROSS FLOOR AREA ABOVE-GRADE STRUCTURE TRACT I	192,900 SF
GROSS FLOOR AREA BELOW-GRADE STRUCTURE TRACT I	25,000 SF
PARKING GARAGE	83,700 SF
PARKING SPACES - LEVEL B1*	66
PARKING SPACES - LEVEL B2*	69
ACCESSIBLE PARKING (INCLUDED)*	6
TOTAL GARAGE PARKING SPACES*	135
TOTAL SURFACE R.O.W. PARKING SPACES	110

AREA SUMMARY CONTINUED	
EXISTING AND NEW (CONDITIONED)	192,900 SF
FLOOR AREA RATIO ***	.9

*PARKING NUMBERS ARE APPROXIMATE AT THIS CONCEPTUAL PHASE
 **DEVELOPMENT BOUNDARY EQUALS AREA INSIDE OF PROPERTY LINE AT GRADE
 BUILDING HEIGHT - 65'-0" (EXCEPT STEEPLES, MECHANICAL ETC. - SEE P.D.)

*** CONDITIONED SPACE ABOVE GRADE / PROPERTY AREA = F.A.R.

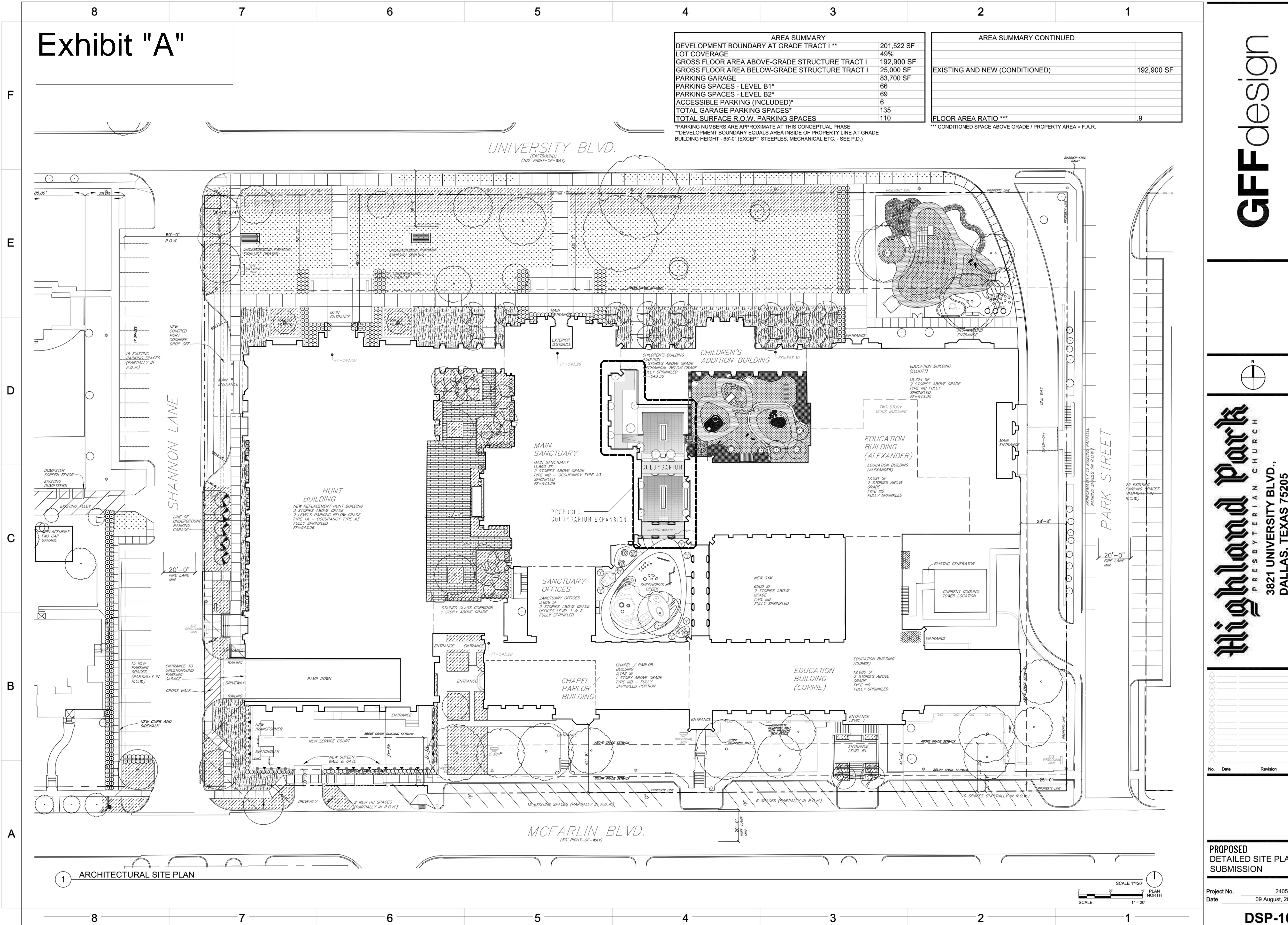

1 ARCHITECTURAL SITE PLAN

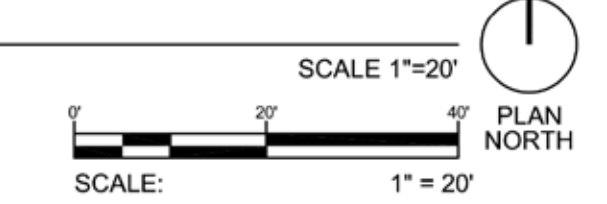

GFFdesign

Highland Park
 PRESBYTERIAN CHURCH
 3821 UNIVERSITY BLVD.,
 DALLAS, TEXAS 75205
COLUMBARIUM EXPANSION

PROPOSED
 DETAILED SITE PLAN
 SUBMISSION

Project No. 24055.00
 Date 09 August, 2024

DSP-101
 © Copyright 2023

DISCLAIMER: RENDERING ON THIS SHEET MAY NOT REPRESENT THE MOST CURRENT DESIGN

SITE

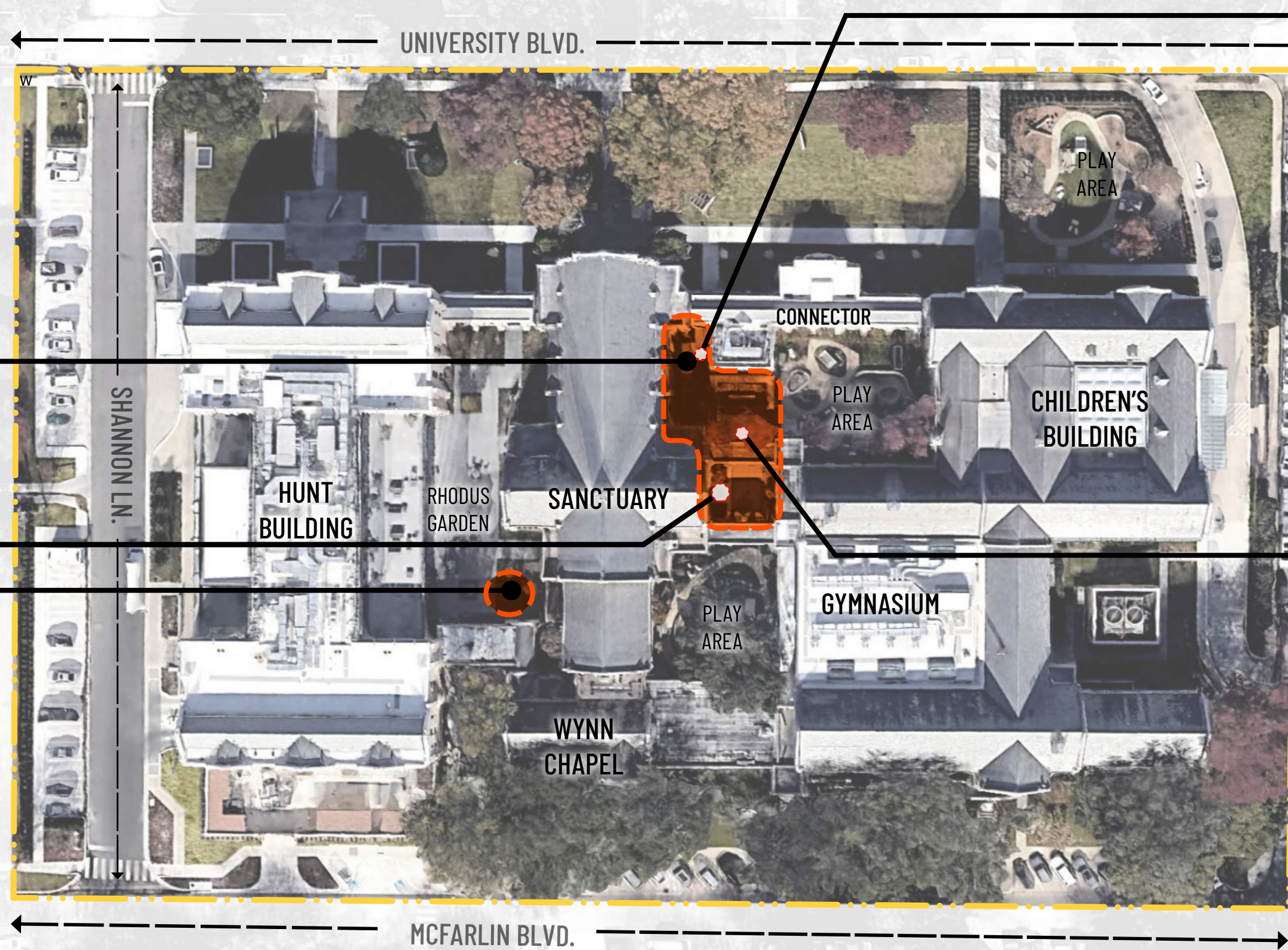

PROPOSED SCULPTURE RELOCATION (INTERNAL COURT-YARD, NOT VISIBLE FROM UNIVERSITY BLVD.)



"ANGEL" SCULPTURE 60"W X 78"T

"ANGEL" SCULPTURE EXISTING LOCATION

PROPOSED COLUMBARIUM EXPANSION (INTERNAL COURT-YARD, NOT VISIBLE FROM UNIVERSITY BLVD.)

"SHEPARD'S REST" SCULPTURE EXISTING LOCATION

PROPOSED SCULPTURE RELOCATION (INTERNAL COURT-YARD, NOT VISIBLE FROM UNIVERSITY BLVD.)



"SHEPARD'S REST" SCULPTURE 56"L x 45"D x 60"T



PLAN

Exhibit "B"

684 ADDITIONAL NICHES / COLUMBARIUM WALLS 36-90"

- ① NEW RAMP
- ② ENHANCED LANDSCAPING
- ③ ENHANCED LANDSCAPE SCREENING
- ④ ENHANCED PLAZA
- ⑤ WATER FEATURE
- ⑥ ANGEL SCULPTURE

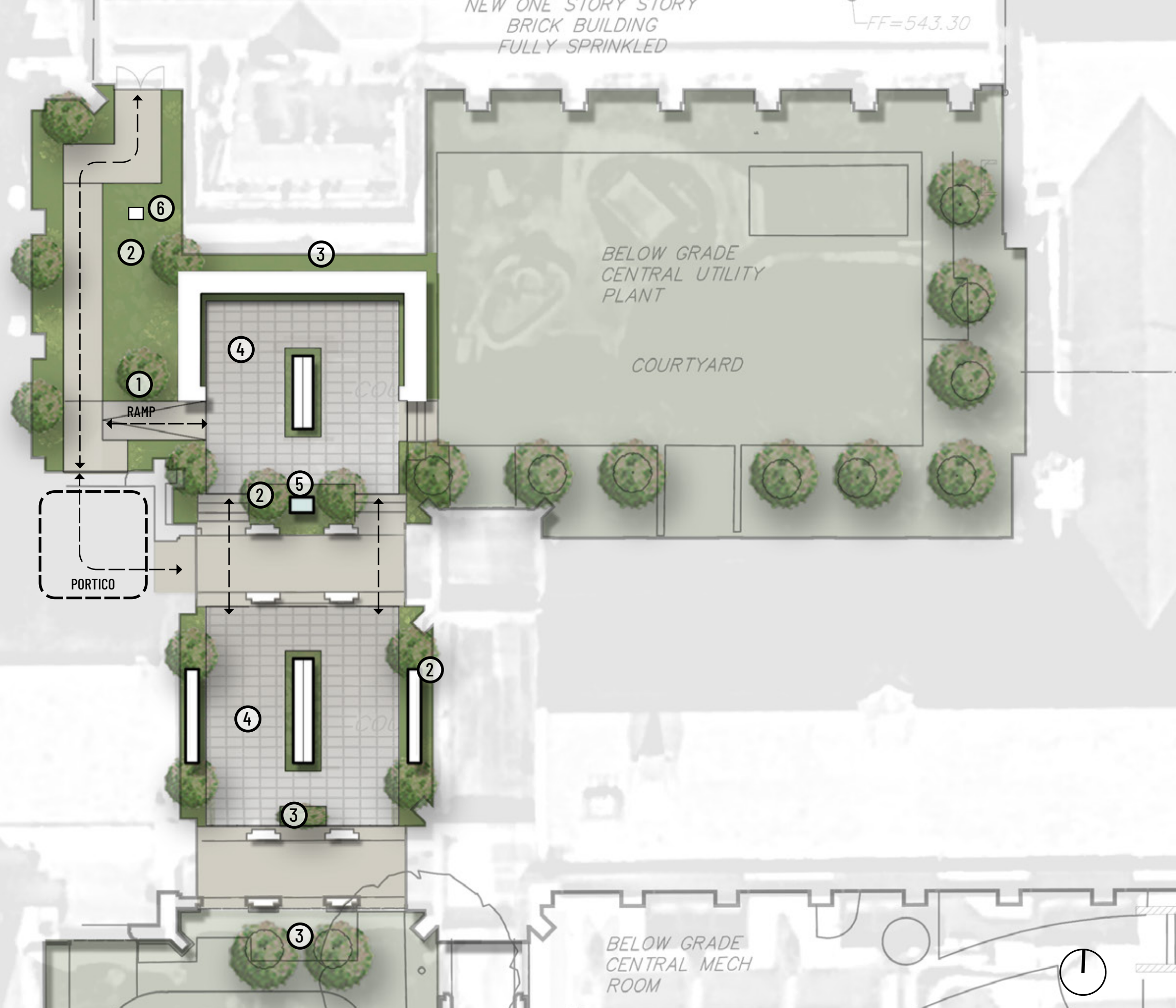

FF=543.29

FULLY SPRINKLED

PLAN

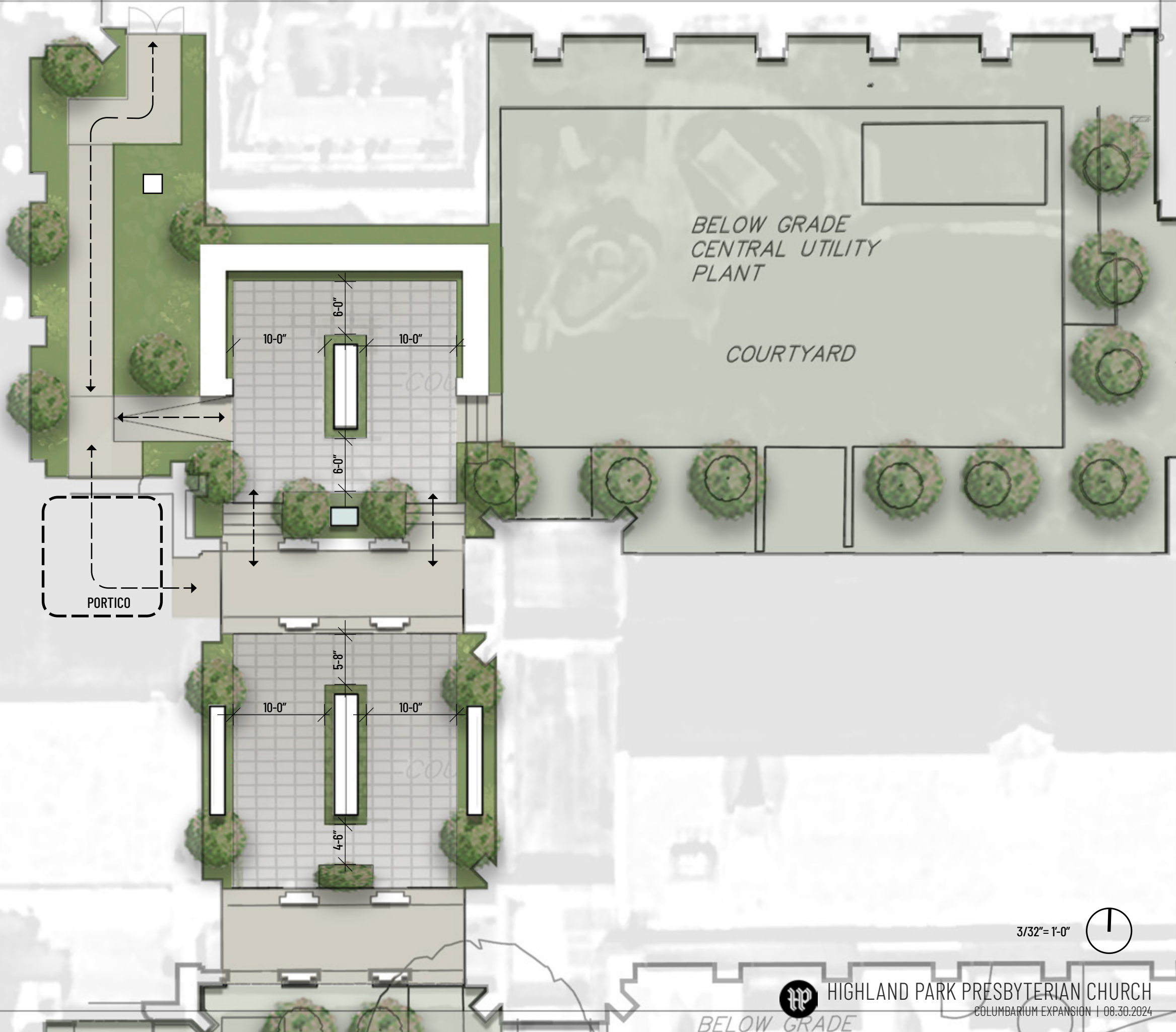

EXISTING MAIN SANCTUARY
 11,890 SF
 2 STORIES ABOVE GRADE
 TYPE IIIB – OCCUPANCY TYPE A3
 NOT CURRENTLY SPRINKLED
 (PROPOSED TO BE SPRINKLED)

3/32" = 1'-0" 

BELOW GRADE

Exhibit "C"

















ELEVATIONS

Exhibit "D"

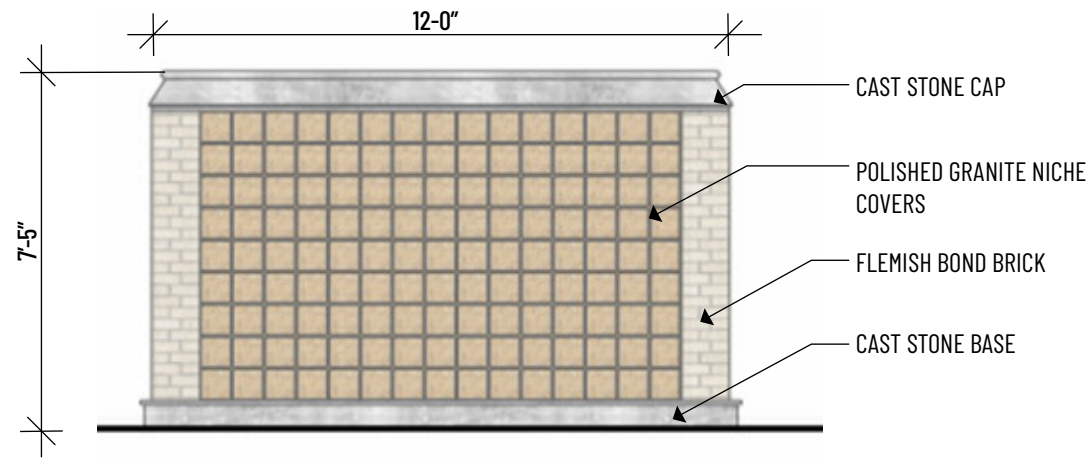

6 EAST SCHOOL COLUMBARIUM WALL (UPPER COURT)
1/4" = 1'-0"

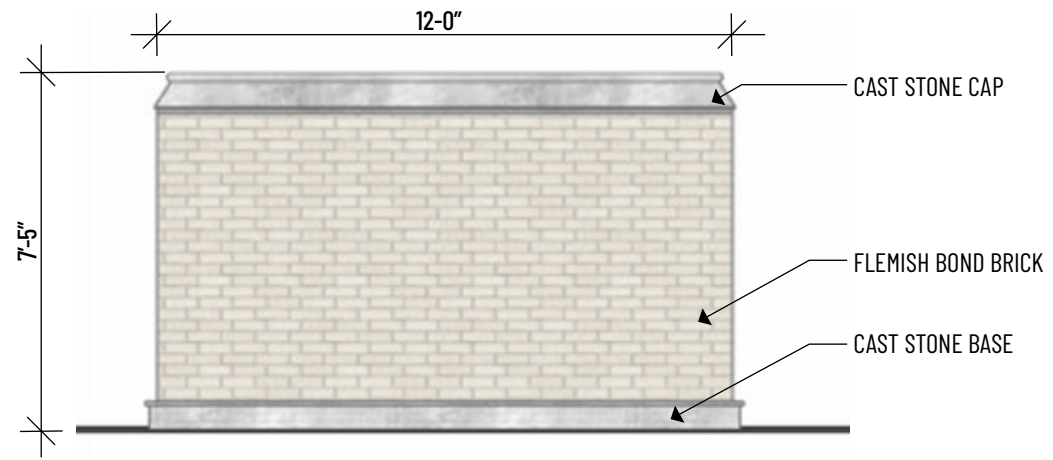

5 WEST SCHOOL COLUMBARIUM WALL (UPPER COURT)
1/4" = 1'-0"

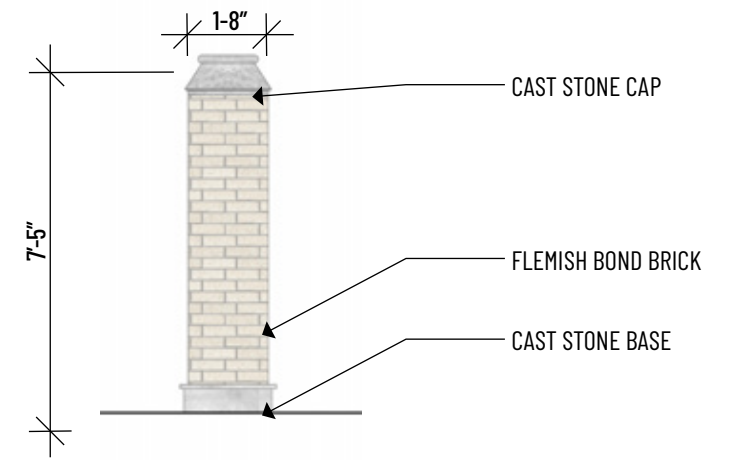

4 NORTH & SOUTH SCHOOL COLUMBARIUM WALL (UPPER COURT)
1/4" = 1'-0"

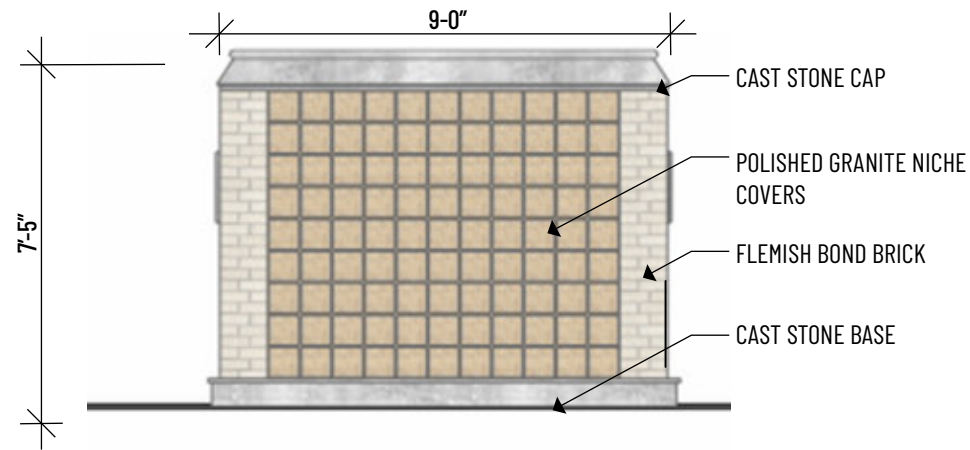

3 EAST CENTER COLUMBARIUM WALL (LOWER COURT)
1/4" = 1'-0"

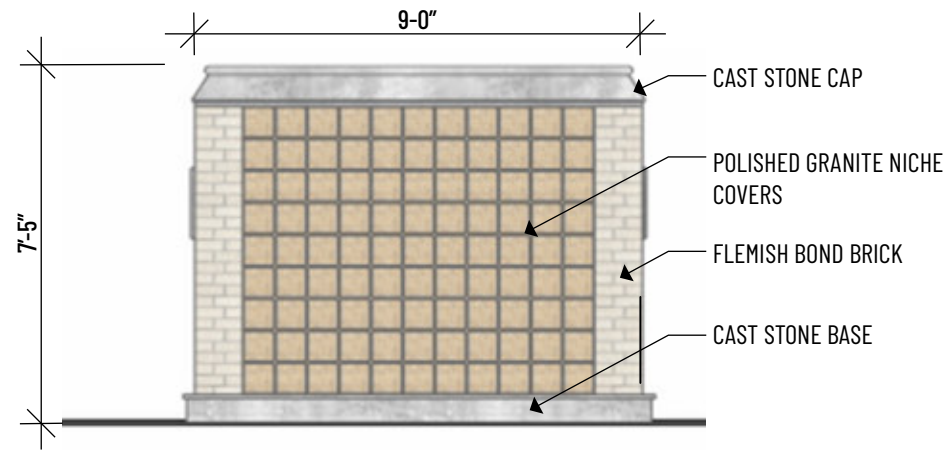

2 WEST CENTER COLUMBARIUM WALL (LOWER COURT)
1/4" = 1'-0"

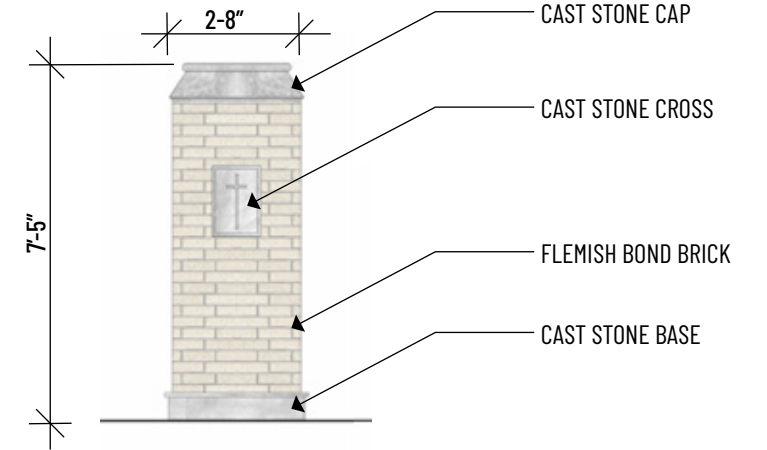

1 NORTH & SOUTH CENTER COLUMBARIUM WALL (LOWER COURT)
1/4" = 1'-0"

ELEVATIONS

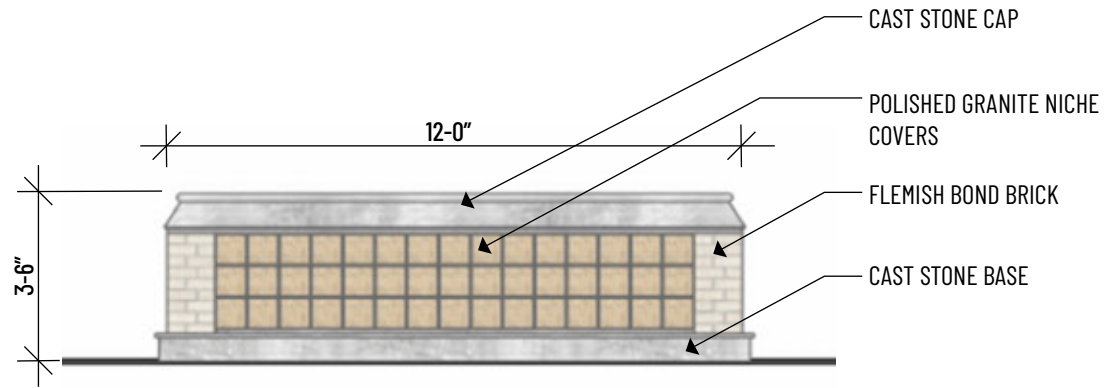

6 WEST SANCTUARY COLUMBARIUM WALL (UPPER COURT)
1/4" = 1'-0"

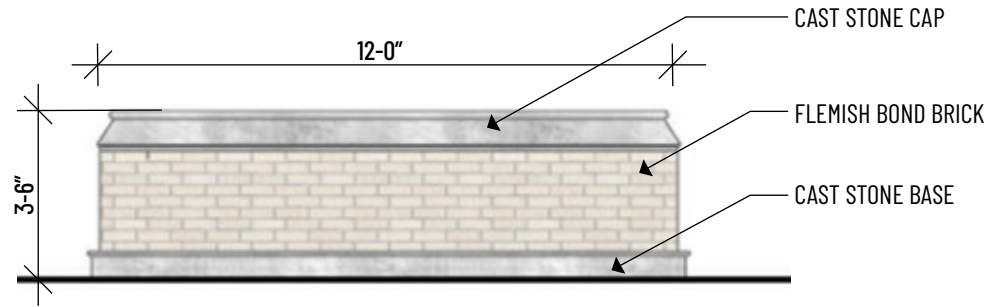

5 EAST SANCTUARY COLUMBARIUM WALL (UPPER COURT)
1/4" = 1'-0"

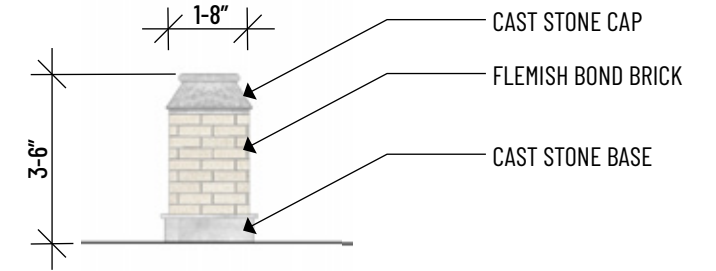

4 NORTH & SOUTH SANCTUARY COLUMBARIUM WALL (UPPER COURT)
1/4" = 1'-0"

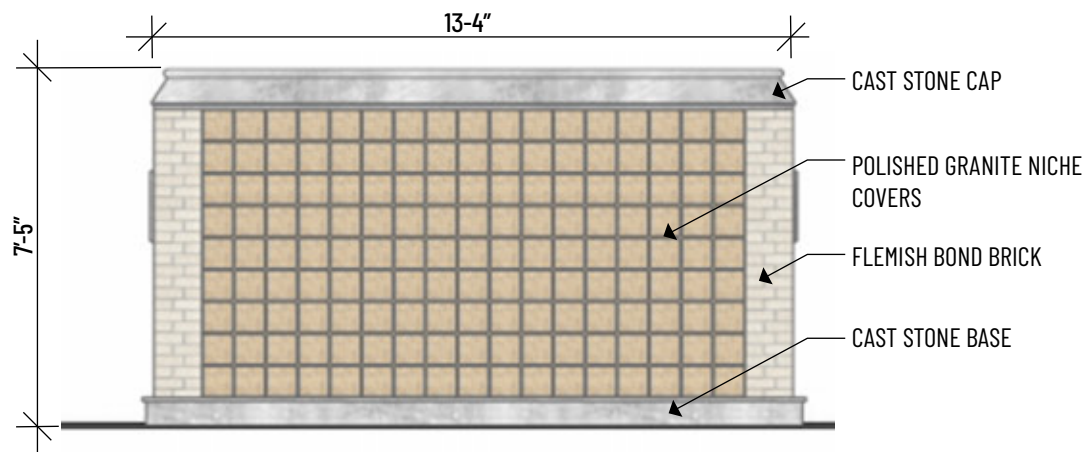

3 WEST CENTER COLUMBARIUM WALL (UPPER COURT)
1/4" = 1'-0"

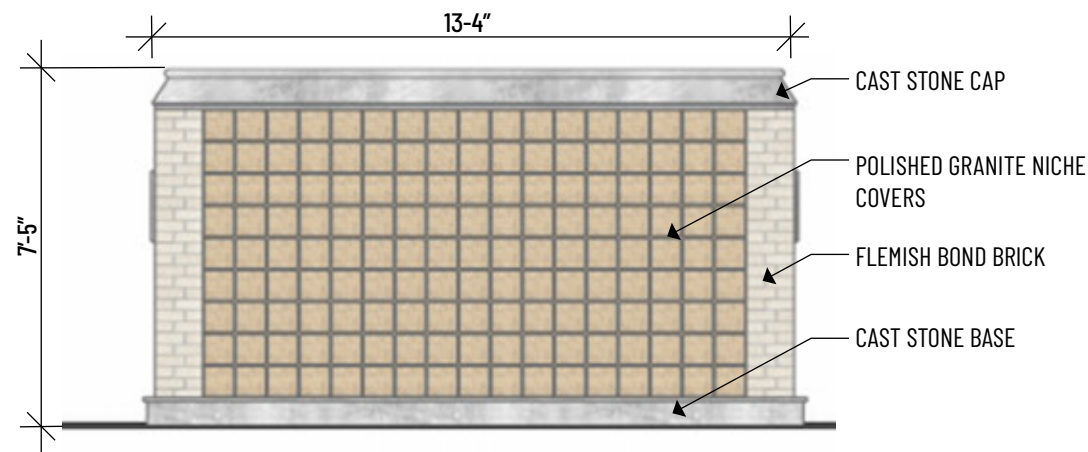

2 EAST CENTER COLUMBARIUM WALL (UPPER COURT)
1/4" = 1'-0"

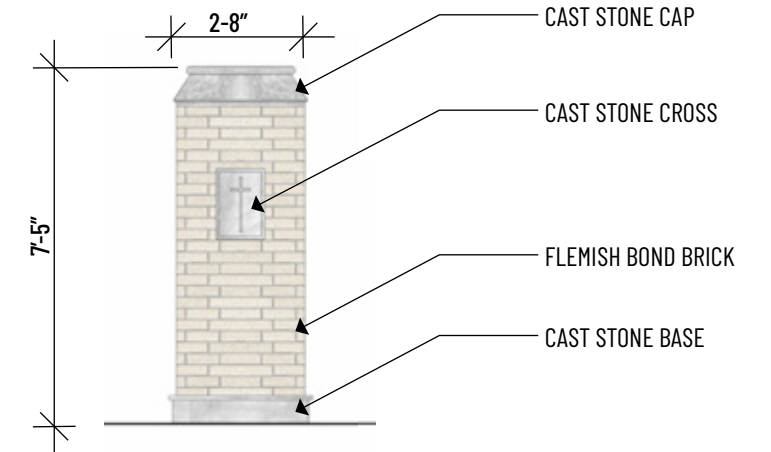

1 NORTH & SOUTH CENTER COLUMBARIUM WALL (UPPER COURT)
1/4" = 1'-0"

MATERIALS



ACME BRICK
45% BLEND 51 (SOUTHERN CLASSIC)
45% BLEND 58 (SHAMROCK)
10% BLEND 501 (MISSION ONE)



EICKHOF COLUMBUMBARIA
NICHE FACE
GOLDEN BRASIL GRANITE
POLISHED



DALLAS CAST STONE CO.
CAST STONE TO MATCH
EXISTING



PAVESTONE
HOLLAND STONE
CHARCOAL



ORNAMENTAL IRON

SHEPARD'S REST SCULPTURE RELOCATION

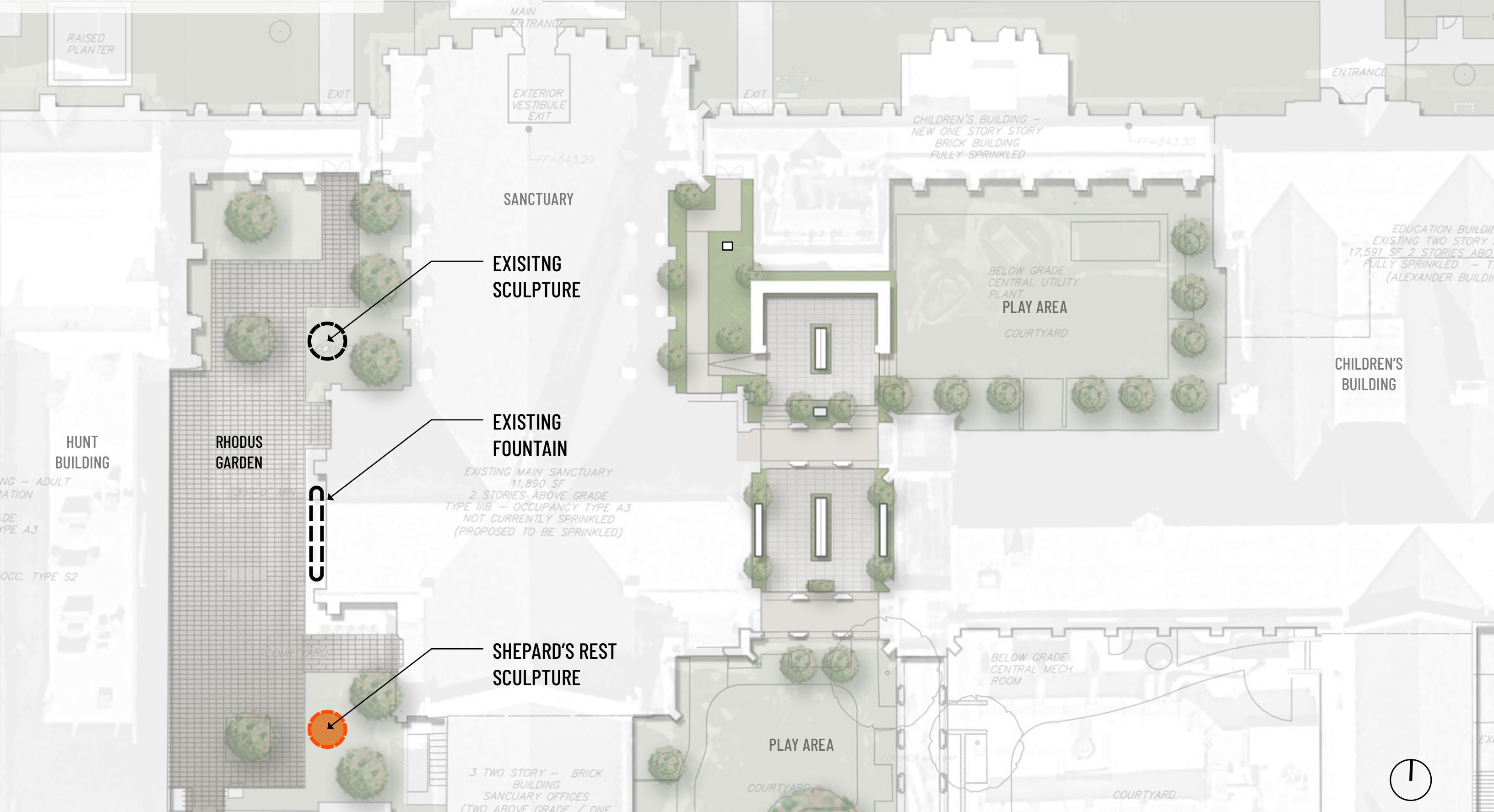

WATER FEATURE

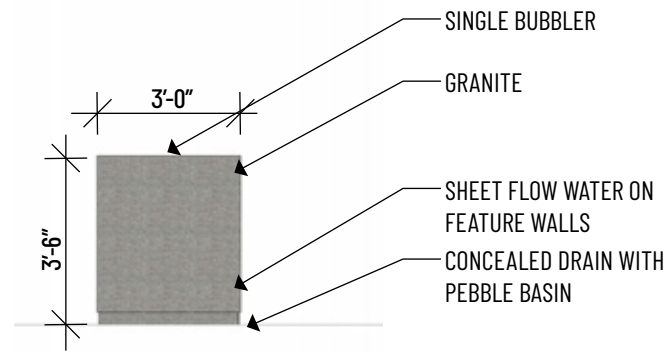

⑥ SOUTH ELEVATION (LOWER COURT)
1/4" = 1'-0"

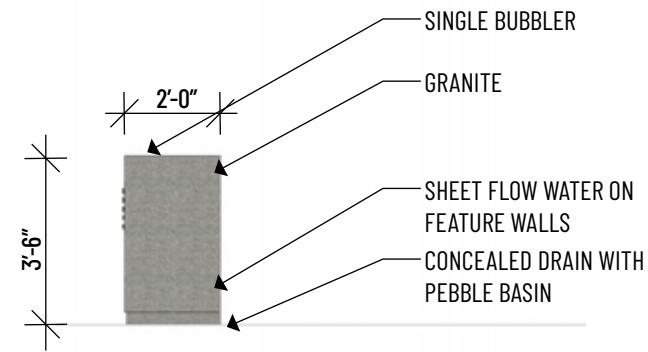

⑤ EAST & WEST ELEVATION (LOWER COURT)
1/4" = 1'-0"

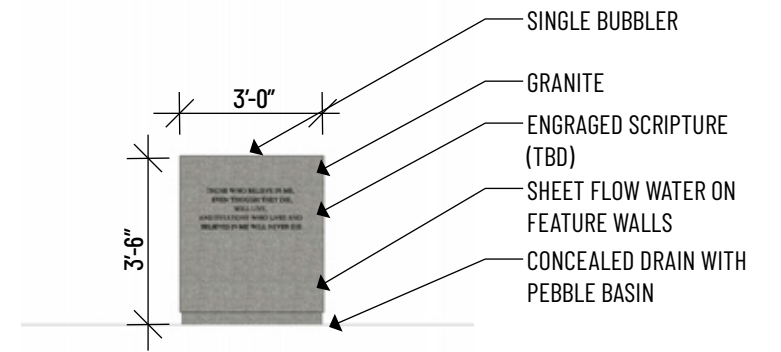

④ NORTH ELEVATION (LOWER COURT)
1/4" = 1'-0"



③ EXAMPLE WATER FEATURE



② RHODUS GARDEN WATER FEATURE



① PLAN (LOWER COURT)
3/32" = 1'-0"

